

SCREWVAC SD 2500

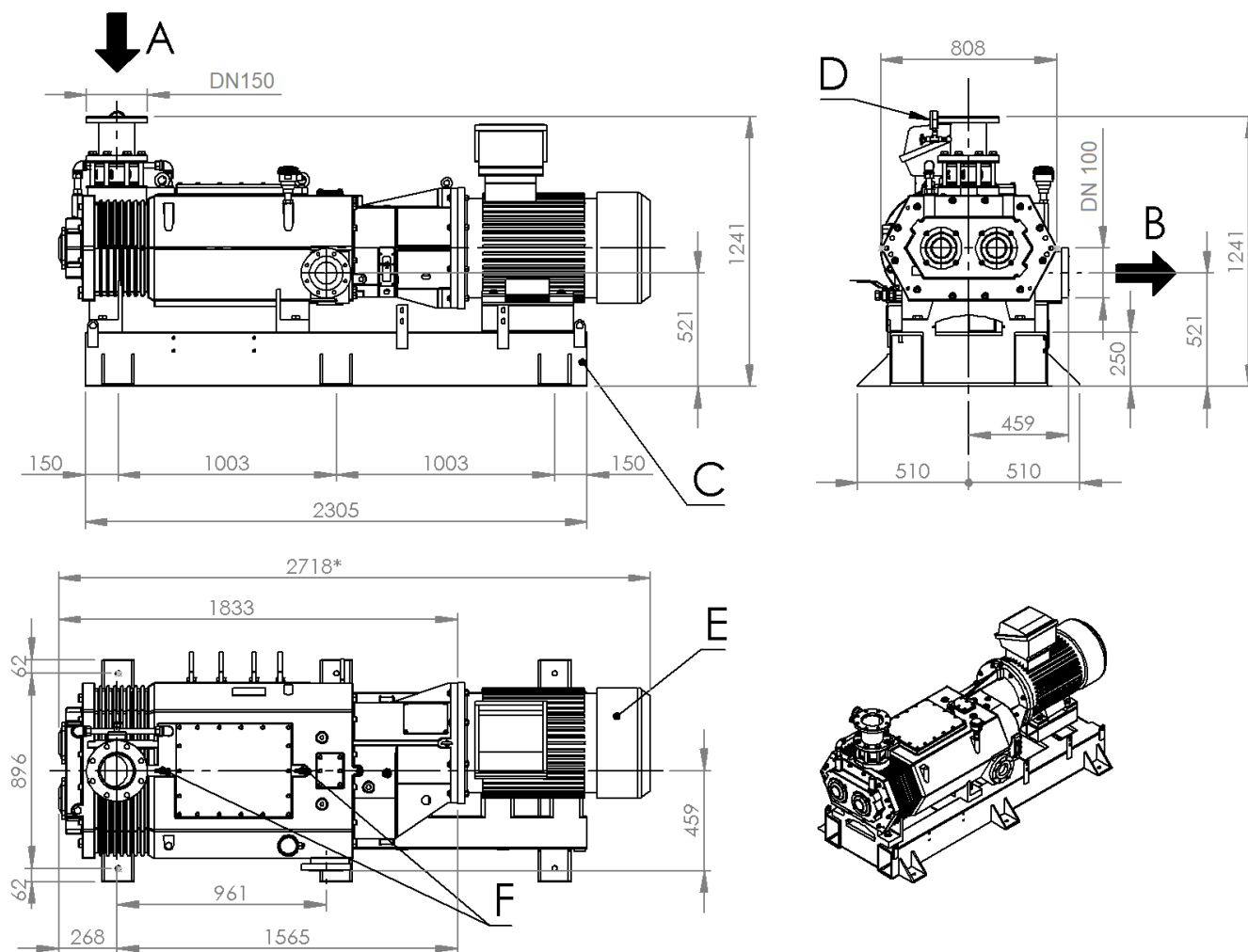

**Misure soggette a variazioni in funzione della marca del motore
 *Dimensions subject to changes depending on the motor brand
 *Données sujettes aux variations en fonction de la marque du moteur
 *Die Maße können aufgrund von Motorzeichen ändern
 Medidas sujetas a variación en función de la marca del motor

I

GB

F

D

E

A	Aspirazione	inlet	Aspiration	Einlass	Aspiración
B	Scarico aria	Exhaust	Sortie de l'air	Luftauslass	Salida de aire
C	Basamento	Baseplate	Base	Untergestell	Base
D	Indicatore di vuoto	Vacuum indicator	Indicateur de vide	Vakuumanzeige	Indicador de vacío
E	Motore elettrico	Electric motor	Moteur électrique	Elektromotor	Motor electrico
F	Golfaro di sollevamento	Lifting eyebolt	Anneau de levage	Aufhebenönschraube	Gancho de levantamiento



**SCHEDA TECNICA
 DATA SHEET
 FICHE TECHNIQUE
 TECHNISCHE KARTE
 ESQUEMA TECNICO**

**SCREWVAC
 SD 2500**

Pag.: 1/2

Data:
 01/2021

ST4848.00

		SCREVVAC SD 2500	
Portata nominale* Nominal speed* Débit nominal* Nennsaugvermögen* Caudal nominal*	m ³ /h	50Hz	2250
		60Hz	2700
Pressione finale*(assoluta) Ultimate pressure* (abs.) Pression limite* (abs.) Enddruck* (abs.) Presión final* (abs.)	mbar (Torr)	50Hz	< 0,07 (< 0,05)
		60Hz	
Potenza motore # / Numero di giri Motor power # / Rotational speed Puissance moteur # / Numéro de révolutions Motorleistung # / Drehzahl Potencia motor # / Velocidad de giro	kW	50Hz ~3	45
	min ⁻¹		1450
	kW	60Hz ~3	55
	min ⁻¹		1750
Caratteristiche motore elettrico Electric motor characteristics Caractéristiques moteur électrique Motoreigenschaften Características motor eléctrico		50Hz ~3	IM B35 400/690 V±10%
		60Hz ~3	IM B35 480/828 V±10%
Livello di pressione acustica Sound pressure level Niveau de pression acoustique Schalldruckpegel Nivel de presión acústica	dB(A) EN ISO 2151	50Hz	< 82
		60Hz	< 84
Acqua di raffreddamento (@ 15°C) Cooling water (@ 15°C) Eau de refroidissement (@ 15°C) Kühlwasser (@ 15°C) Agua de enfriamiento (@ 15°C)	l/min		40 - 50
Carica olio Oil capacity Charge d'huile Ölfüllmenge Carga de aceite	l		10
Peso totale Total weight Poids total Gesamtgewicht Peso total	kg	Bareshaft	2250

*Secondo accordi PNEUROP 6602.
*According to PNEUROP standard 6602.
*Selon la norme PNEUROP 6602.
*Nach der PNEUROP Norm 6602.
*Según la normativa PNEUROP 6602.

#Valido per temperature fino a 40°C e altitudini inferiori a 1000 m.
#Valid for temperatures up to 40°C and altitudes lower than 1000 m.
#Valable pour températures jusqu'à 40°C et pour altitudes inférieures à 1000 m.
#Gültig für Temperaturen bis 40°C und für Höhen weniger als 1000 m.
#Válido para temperaturas hasta 40°C y altitudes inferiores a 1000 m.

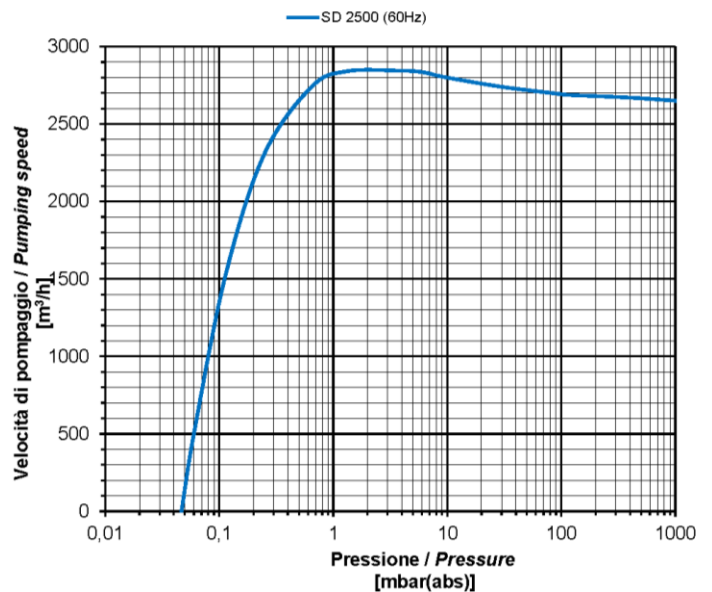
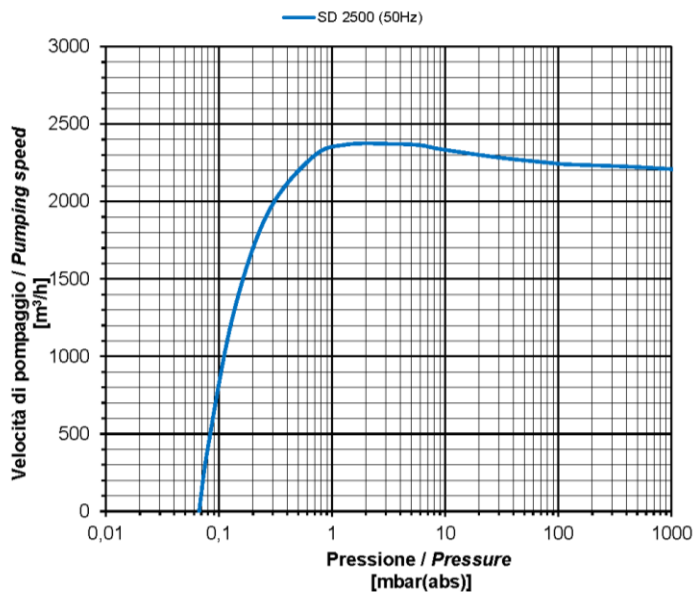

SCHEDA TECNICA
DATA SHEET
FICHE TECHNIQUE
TECHNISCHE KARTE
ESQUEMA TECNICO

SCREVVAC
SD 2500

Pag.: 2/2

Data:
01/2021

ST4848.00