

# SCREWVAC SD 250

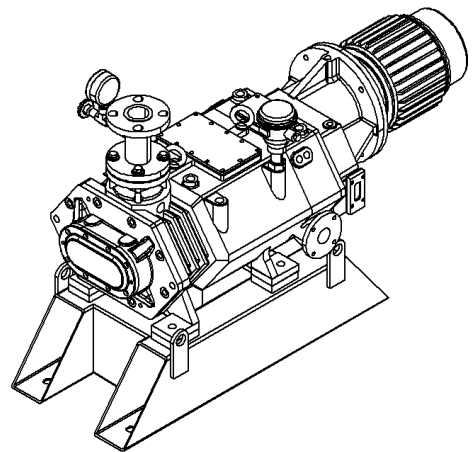
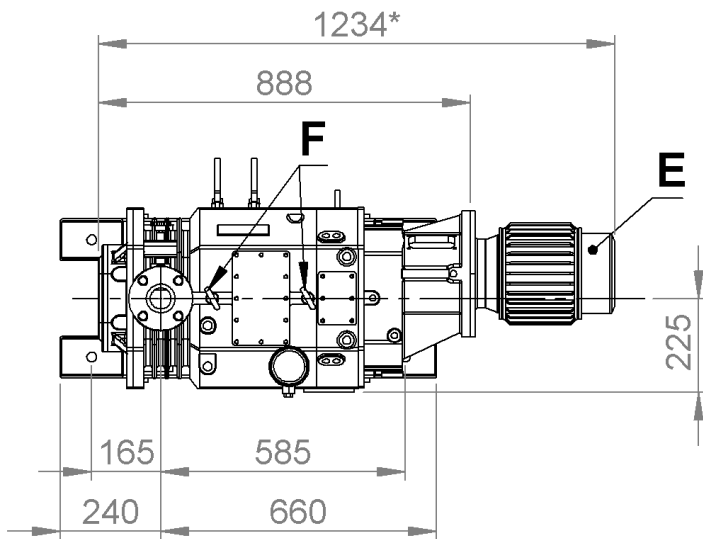
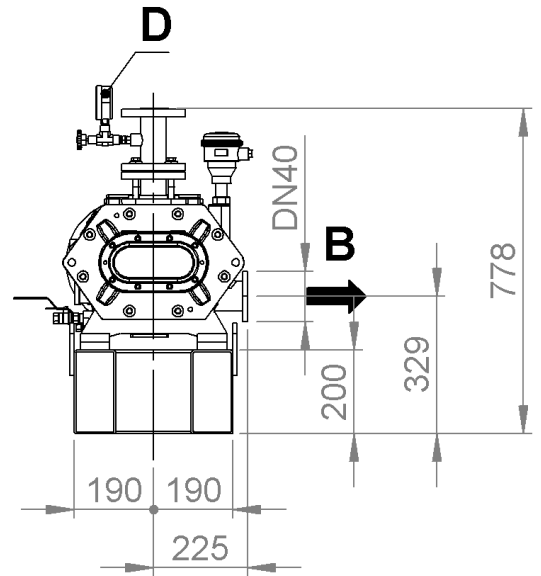
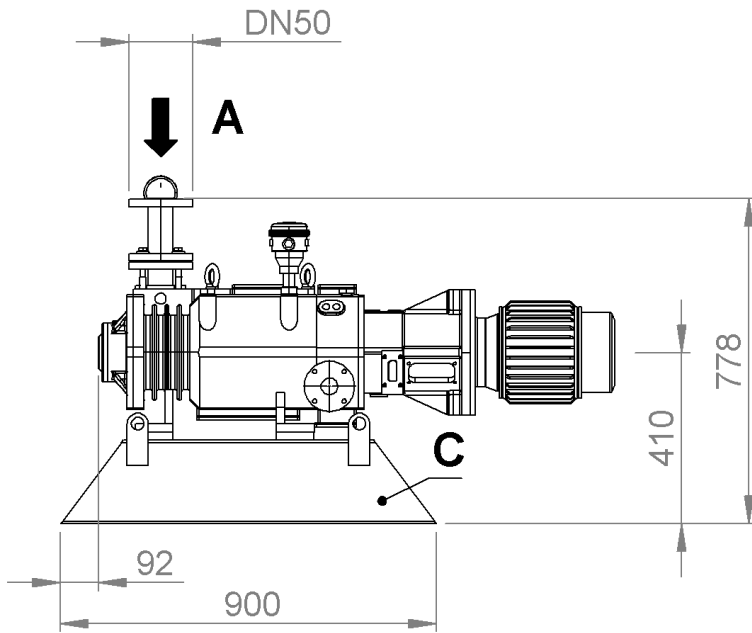

*\*Misure soggette a variazioni in funzione della marca del motore  
 \*Dimensions subject to changes depending on the motor brand  
 \*Données sujettes aux variations en fonction de la marque du moteur  
 \*Die Maße können aufgrund von Motorzeichen ändern  
 \*Medidas sujetas a variación en función de la marca del motor*

I

GB

F

D

E

<b>A</b>	Aspirazione	inlet	Aspiration	Einlass	Aspiración
<b>B</b>	Scarico aria	Exhaust	Sortie de l'air	Luftauslass	Salida de aire
<b>C</b>	Basamento	Baseplate	Base	Untergestell	Base
<b>D</b>	Indicatore di vuoto	Vacuum indicator	Indicateur de vide	Vakuumanzeige	Indicador de vacío
<b>E</b>	Motore elettrico	Electric motor	Moteur électrique	Elektromotor	Motor electrico
<b>F</b>	Golfaro di sollevamento	Lifting eyebolt	Anneau de levage	Aufhebenönschraube	Gancho de levantamiento



**SCHEDA TECNICA**  
**DATA SHEET**  
**FICHE TECHNIQUE**  
**TECHNISCHE KARTE**  
**ESQUEMA TECNICO**

**SCREWVAC**  
**SD 250**

Pag.: 1/2

Data:  
 01/2021

**ST4883.00**

		SCREVVAC SD 250	
Portata nominale* Nominal speed* Débit nominal* Nennsaugvermögen* Caudal nominal*	m <sup>3</sup> /h	50Hz	250
		60Hz	300
Pressione finale*(assoluta) Ultimate pressure* (abs.) Pression limite* (abs.) Enddruck* (abs.) Presión final* (abs.)	mbar (Torr)	50Hz	< 0,01 (< 0,0075)
		60Hz	
Potenza motore # / Numero di giri Motor power # / Rotational speed Puissance moteur # / Numéro de révolutions Motorleistung # / Drehzahl Potencia motor # / Velocidad de giro	kW	50Hz ~3	7,5
	min <sup>-1</sup>		2900
	kW	60Hz ~3	7,5
	min <sup>-1</sup>		3500
Caratteristiche motore elettrico Electric motor characteristics Caractéristiques moteur électrique Motoreigenschaften Características motor eléctrico		50Hz ~3	IM B5 400/690 V±10%
		60Hz ~3	IM B5 480/828 V±10%
Livello di pressione acustica Sound pressure level Niveau de pression acoustique Schalldruckpegel Nivel de presión acústica	dB(A) EN ISO 2151	50Hz	< 77
		60Hz	< 79
Acqua di raffreddamento (@ 15°C) Cooling water (@ 15°C) Eau de refroidissement (@ 15°C) Kühlwasser (@ 15°C) Agua de enfriamiento (@ 15°C)	l/min		10 - 15
Carica olio Oil capacity Charge d'huile Ölfüllmenge Carga de aceite	l		2
Peso totale Total weight Poids total Gesamtgewicht Peso total	kg	Bareshaft	350

\*Secondo accordi PNEUROP 6602.  
\*According to PNEUROP standard 6602.  
\*Selon la norme PNEUROP 6602.  
\*Nach der PNEUROP Norm 6602.  
\*Según la normativa PNEUROP 6602.

#Valido per temperature fino a 40°C e altitudini inferiori a 1000 m.  
#Valid for temperatures up to 40°C and altitudes lower than 1000 m.  
#Valable pour températures jusqu'à 40°C et pour altitudes inférieures à 1000 m.  
#Gültig für Temperaturen bis 40°C und für Höhen weniger als 1000 m.  
#Válido para temperaturas hasta 40°C y altitudes inferiores a 1000 m.

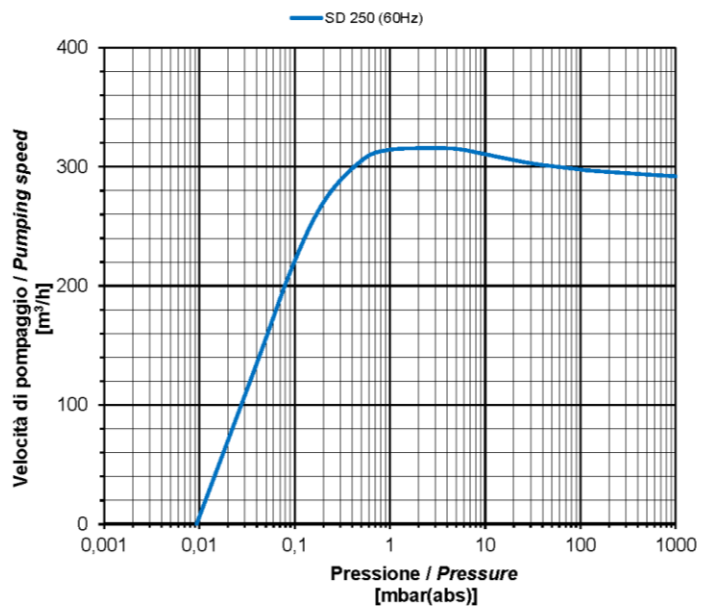
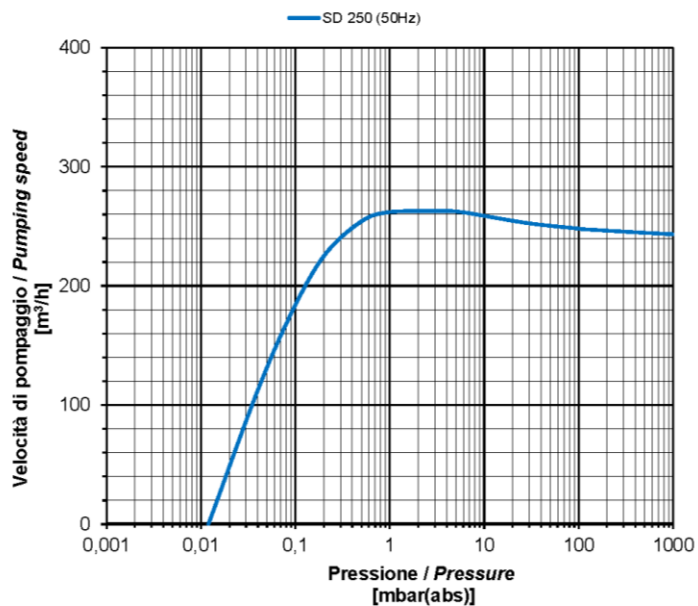

SCHEDA TECNICA  
DATA SHEET  
FICHE TECHNIQUE  
TECHNISCHE KARTE  
ESQUEMA TECNICO

SCREVVAC  
SD 250

Pag.: 2/2

Data:  
01/2021

ST4883.00